

# 4<sup>th</sup> ANNUAL FLEET MANAGEMENT

Advancing vehicular tracking through smart integration  
24th – 25th October 2018 | Pullman Bangkok Grande Sukhumvit, Thailand

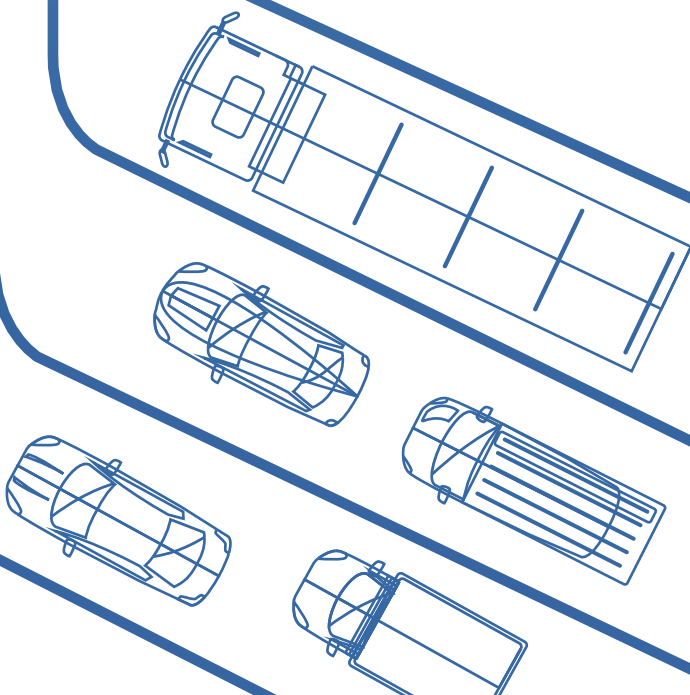

# 4<sup>TH</sup> ANNUAL FLEET MANAGEMENT

Advancing vehicular tracking through smart integration

24th - 25th October 2018 | Pullman Bangkok Grande Sukhumvit, Thailand

“All our intelligence suggests that monitoring by telematics is increasingly accepted as a fact of life and the benefits more fully understood.”

- Ralph Morton, Editorial Director of Business Car Manager

## EVENT OVERVIEW

The rise of integrated connectivity technology had contributed to the enhancement of capabilities for fleet management operations to access real-time data from each and every vehicle deployed in the field. Fleet telematics plays a crucial role in ensuring improvements in safety, service and maintenance costs, and compliance. Quartz reported that 25GB of data are uploaded every hour to assist fleet managers in executing operational decisions with greater efficacy. As fleet sizes began to quadruple exponentially, intelligent and accessible data is generating new fleet management models designed to enhance fleet service, fleet maintenance, fleet repair and driver behaviour.

With correct application, telematics capabilities fitted into fleet management system brings advantages in valuable insights into consumer preferences and a seamless, intuitive fleet experience. The introduction of telematics in the operational aspect of Andrew Page, a 900-vehicle fleet company that distributes tools, parts and equipment in the UK, led to a 97% reduction in speeding, around 7% better fuel economy, a 47% reduction in crashes and other incidents and reduced maintenance costs.

Together with cost reduction results and efficient processes, the **4th Annual Fleet Management by Trueventus** features the key elements in achieving the highest value through deep analysis in fleet data and productive automation of vehicles. Connectivity is uniting the massive assets and sectors in fleet management while falling behind in fallible past infrastructures are detrimental to the business. Dive in to the efficient frameworks and processes from specialists and major industry players from a complex and in-depth conference.

## WHY YOU CANNOT MISS THIS EVENT

- Discover the latest 4.0 technology integration into existing telematics system in pursuit of improving operational and vehicle management infrastructure
- Gauging the profitability and efficiency aspect revolving around fleet maintenance and service
- Learning the method to properly scan through huge amount of fleet data to generates insights in making accurate decisions when running and controlling vehicles
- Understanding the complexities of fleet system operation and applying the best methods to replace existing fleet
- Scoping the challenges to employing contingencies for risks while collaborating with other parties for procurement and productivity tasks

## WHO SHOULD ATTEND?

This event is targeted but not limited to:

- CEOs, COOs & CFOs
- VPs/Directors/Heads of:
  - Operation
  - Purchasing
  - Fleet Operation
  - Management
  - Regional
  - Executive
  - Project

From the following industries:

- Logistics companies
- Postal services
- Oil & Gas transportation
- Food manufacturing
- Retailers
- Utilities
- Telecommunications
- Aviation
- Garbage disposal
- Government bodies
- Mining
- Vehicle rental & leasing services

## ASSOCIATE PARTNERS



# 4<sup>TH</sup> ANNUAL FLEET MANAGEMENT

Advancing vehicular tracking through smart integration

24th - 25th October 2018 | Pullman Bangkok Grande Sukhumvit, Thailand

## Conference at a glance

### Day One: Wednesday, 24th October 2018

- 0800 **Registration & coffee**
- 0850 **Opening keynote address**
- 0900 **Session One**  
Leveraging Blockchain technology in fleet management capacity to capture the full value of decentralised system
- 0945 **Session Two**  
Managing oil and gas fleet risk through solutions designed to help improve safety profiles and reduce crash
- 1030 **Speed networking**
- 1045 **Morning refreshment**
- 1115 **Session Three**  
Redefining fleet management landscape with the promulgation and adaptation of Internet of Things
- 1200 **Session Four**  
Powering up operational fleet efficiency and productivity through artificial intelligence-equipped system
- 1245 **Networking luncheon**
- 1400 **Session Five**  
Distraction Kills: Underpinning the importance of safety assurance for human assets on the road
- 1445 **Session Six**  
Ethics & Algorithms: Ensuring sensitivity to privacy of data assets according to standard and compliance
- 1530 **Afternoon refreshment**
- 1600 **Session Seven**  
Addressing contemporary shipping challenges through game changing software solutions
- 1630 **Session Eight**  
Balancing HR needs in fleshing out the best strategy to ensure higher productivity among fleet, workshop, and labour
- 1730 **Session Nine**  
Mitigating airline fleet growth in the Asia-Pacific aviation boom through the advancement of infrastructure and labour capacity
- 1730 **End of day one**

### Day Two: Thursday, 25th October 2018

- 0800 **Registration & coffee**
- 0850 **Opening keynote address**
- 0900 **Session One**  
Estimating wider economic benefits for Singapore-Malaysia high speed rail link with seamless fleet management and positioning
- 0945 **Session Two**  
Strategizing optimum replacement blueprint for business fleets according to various standards applied to different vehicle types
- 1030 **Speed networking**
- 1045 **Morning refreshment**
- 1115 **Session Three**  
Balancing the need to preserve clean ocean and shipping fleets profit motive to ensure environmentally-conscious standard of operation
- 1200 **Session Four**  
Recalibrating contemporary economic and operational model of fleet management in the globalized supply chain
- 1245 **Networking luncheon**
- 1400 **Session Five**  
Mobility Management: Orientating rental car fleet operations to be in-line with the consumer-centric zeitgeist
- 1445 **Session Six**  
Identifying key areas for telematics application across myriad of industries to showcase higher versatility and interoperability
- 1530 **Afternoon refreshment**
- 1600 **Session Seven**  
Disrupting current automotive business model to cater to rising autonomous bend by injecting mass ownerships of self-driving cars
- 1645 **Session Eight**  
Integrating rental fleet business blueprint with booming ride services to adapt to current automotive landscape
- 1700 **Session Nine**  
Framing tracking technology to reinvigorates telecommunications industry by fitting defining edge with telematics attributes
- 1730 **End of conference**

# 4<sup>TH</sup> ANNUAL FLEET MANAGEMENT

Advancing vehicular tracking through smart integration  
24th - 25th October 2018 | Pullman Bangkok Grande Sukhumvit, Thailand

## COMPANY DETAILS

Name	Industry
Address	
Postcode	Country
Tel	Fax

## ATTENDEE DETAILS

<b>1</b>	Name	Job Title
	Tel	Email
<b>2</b>	Name	Job Title
	Tel	Email
<b>3</b>	Name	Job Title
	Tel	Email
<b>4</b>	Name	Job Title
	Tel	Email
<b>5</b>	Name	Job Title
	Tel	Email

## APPROVAL

NB: Signatory must be authorised on behalf of contracting organisation.

Name	Job Title
Email	
Tel	Fax
Authorising Signature	

## COURSE FEES (20% DISCOUNT FOR SUPPLY CHAIN & LOGISTICS GROUP)

	<b>Corporate</b>
<b>End of July 2018</b>	<b>USD 2195</b>
<b>End of August 2018</b>	<b>USD 2395</b>
<b>1st September 2018 onwards</b>	<b>USD 2495</b>
<input type="checkbox"/> Document Package USD 495	
All options inclusive of delegate pack, luncheon and refreshments.	

**BK-MF10**

## PAYMENT DETAILS

Payment is due in 5 working days. By Signing and returning this form, you are accepting our terms and conditions.

Please debit my:  VISA  MasterCard

Card Number

CVC/CW2    *This three-digit CVC/CW2 number is printed on the signature panel on the back of the card immediately after the card's account number.*

Card Issuing Bank: \_\_\_\_\_ Card Issuing Country: \_\_\_\_\_

Cardholder's Name: \_\_\_\_\_ Expiry Date: \_\_\_\_\_ / \_\_\_\_\_ / \_\_\_\_\_

Cardholder's Signature: \_\_\_\_\_ Cardholder's Email: \_\_\_\_\_

## REGISTER NOW

**Saqib Jugnu**  
**T: +603 2775 0000 Ext: 548**  
**E: saqibj@trueventus.com**  
**Take a Snapshot or Scan and Email us**

## TERMS & CONDITIONS

- The course fee is inclusive of the event proceedings, materials, refreshment and lunch.
- Upon receipt of the complete registration form, invoice will be issued. Trueventus request that all payments be made within 5 working days of the invoice being issued. Full payment must be received prior to the event. Only delegates that have made full payment will be admitted to event. Clients are responsible for their own banking fees and banking fees will not be absorbed into the booking price.
- Substitution & cancellations policy. Should the registered delegate is unable to attend, a substitute delegate is welcome at no extra charge. Written notifications of all substitutions is required 5 working days prior to the event. Trueventus contracts carry 100% full liability upon receipt of registration. Non payment does not constitute cancellation. A 100% of cancellation fee will be charged under the terms outlined below: Due to limited event seats, Trueventus agrees to book and confirm the seat for the client upon issuance of invoice. Upon signing of this contract, client agrees that in case of dispute or cancellation of this contract Trueventus will not be for total contract value. If a client does not attend the event without written notification at least 5 working days prior to the event date, he/she will deemed as no show. A no show at the event still constitutes that the client will have to pay the invoice amount that was issued to them. Trueventus does not provide refunds for cancellations. By signing this contract the client also agrees that if they cancel that Trueventus reserves the right to pursue monies owned via the use of local debt collection agency were the client is situated. Furthermore the client will be held liable for any costs incurred in collection of outstanding monies. When any cancellations are notified in writing to Trueventus 5 working days prior to the event, a credit voucher will be issued for use in future Trueventus events.
- Trueventus will at all times seek to ensure that all efforts are made to adhere to meet the advertised package, however we reserve the right to postpone, cancel or move a venue without penalty or refunds. Trueventus is not liable for any losses or damages as a result of substitution, alteration, postponement or cancellation of speakers and / or topics and / or venue and / or the event dates. If force majeure were to occur Trueventus accepts no responsibility or liability for any loss or damage caused by events beyond their control, including, but not restricted to strikes, war, civil unrest, flight delays, fire flood, or any adverse weather conditions. Trueventus under no circumstances is liable for any other costs that might have been incurred in the attendance of the event, including but not limited to flights, accommodation, transfers, meals etc. Trueventus reserves the right to replace / change speakers in the best interest of the conference.
- Upon receiving this signed booking form, you the client hereby consent to Trueventus to keep your details for the use of future marketing activities carried out by Trueventus and third party organisations & partners.
- Copyright and Intellectual Property. Any redistribution or reproduction of part or all of the contents in any form in connection to this event is prohibited without prior written consent by Trueventus.
- Client hereby agrees that he/she exclusively authorizes Trueventus charged the credit card with details listed above for the amount provided herein; this registration form serves as a contract that is valid, binding and enforceable. He/she at any time will have no basis to claim that the payments required under this Contract are unauthorized, improper, disputed or in any way. Upon issuance of invoice Trueventus will be charging the client USD 30 processing fee.



HRDF claimable under SBL scheme  
**HRDF Approved Training Provider Reg No: 889325K**  
(Applicable for Malaysia only)